

WALL SCONCE

CYLINDER & SQUILINDER LED LUMINAIRE

INSTALLATION

Before beginning installation, disconnect electrical power at main switch or circuit breaker.

A. CAUTION

To reduce the risk of fire, electric shock, and potential damage to recessed housing assembly when electrical power is re-connected, DO NOT ATTEMPT TO CONNECT the following on branch circuit serving recessed downlight assembly:

- Motors
- Power tools
- Extension cords
- Appliances or similar electronics

Fixtures to be mounted in conditions where ambient temperatures do not exceed 40°C.

Ensure AC input voltage is protected against surges & load shifts prior to power supply input.

B. SAFETY INSTRUCTIONS

1. Read installation instructions completely before attempting installation.
2. Failure to follow instructions may result in improper installation and void warranty.
3. Contact Lucifer Lighting Company with any questions or concerns before beginning any installation.
4. Ensure qualified electrician will perform all electrical procedures.
5. Disconnect electrical power circuit before attempting to install sconce, or if adding to or changing configuration of fixture assembly.
6. CAUTION: When fixture is on for long periods the surface may be hot. Take care when making adjustments.

This product must be installed in accordance with applicable electrical and installation codes by a person familiar with the construction and operation of the product and the hazards involved. "CAUTION- RISK OF FIRE"

C. DESCRIPTION

Wall mounted Sconce with dimmable LED module and optional integral or remote driver. Available as down light or up/down light in cylinder or squilinder profiles.

D. MOUNTING

Wall Sconce includes mounting plate with factory supplied hidden screws to mount to single-gang junction box. Accommodates 0.44" (12mm) to 0.75" (19mm) wall thickness.

E. MOUNTING PREPARATION

Wall Sconce includes mounting plate with factory supplied hidden screws to mount to customer furnished single-gang junction box. Mounting plate to be installed after wall is finished accommodating 0.44" (12mm) to 0.75" (19mm) wall thickness.

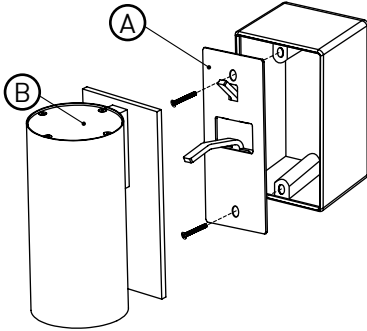

PARTS IDENTIFICATION

<u>Qty.</u>	<u>Description</u>	<u>Part ID</u>
1	Mounting plate	A
1	Sconce	B

NOTE: Mounting plate ships with Sconce assembly.

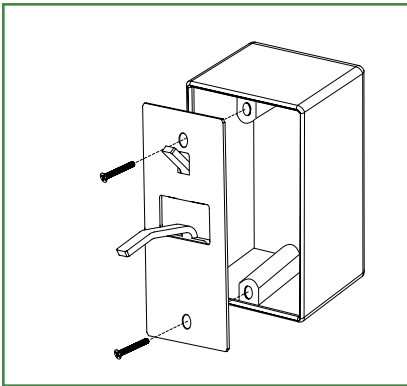

STEP 1

After substrate is installed, mounting plate attaches to single-gang junction box with factory supplied screws.

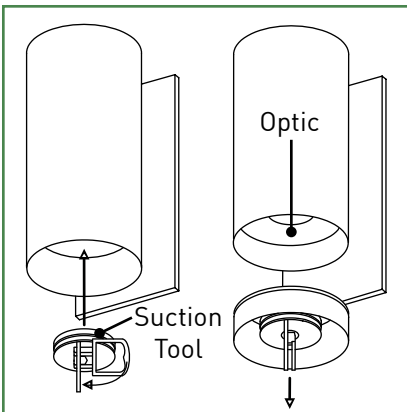

STEP 2

Remove baffle assembly from Sconce by securing suction tool (provided) to lens and gently pulling down to release.

STEP 3

Carefully grab optic and twist counter-clockwise to remove. Set optic and baffle assembly aside in safe location.

F. WIRING / MOUNTING

Ensure mounting plate is installed and wall is finished prior to wiring and mounting Sconce.

Note: If using remote power supply, see page 5.

STEP 1A - UL1598 INSTALLATIONS

Attach wiring from line / mains source as indicated with suitable wire-nuts or similar connectors. For 0-10V dimming option, use gray and purple wires as shown. Push connections and excess wiring through slot opening on mounting plate and into junction box.

Black Wire	- Line
White	- Neutral
Green	- Ground
Purple	- Dim +
Gray	- Dim -

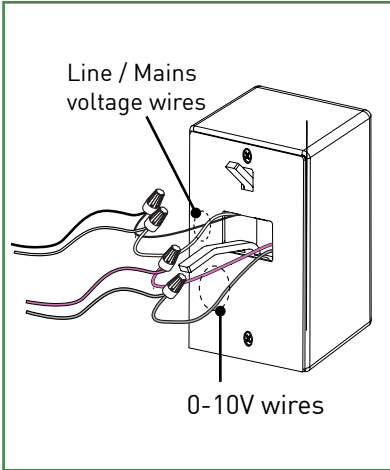

STEP 1A - UL1598 INSTALLATIONS

Attach wiring from low voltage source as indicated with suitable wire-nuts or similar connectors.

Reference Section J for drive current and node compatibility information.

Red Wire	- Positive (+)
Black Wire	- Negative (-)

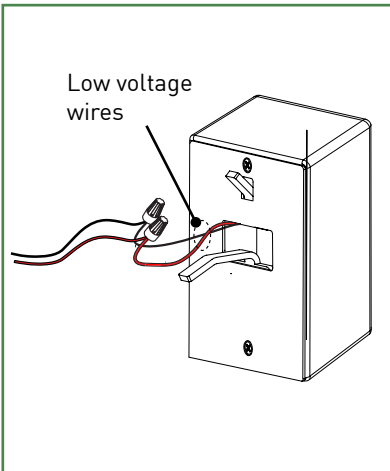

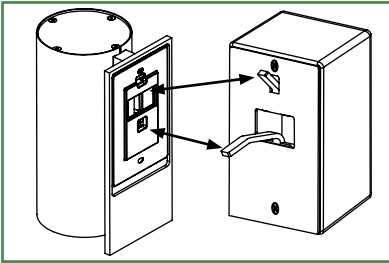

STEP 2

Position arms of mounting plate into slot openings on Sconce assembly. Push Sconce assembly firmly against finished wall.

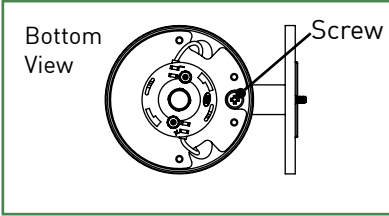

STEP 3

Tighten #2 Phillips screw, accessible from bottom of Sconce, securing Sconce to mounting plate.

Important: Tighten screw until snug; do NOT over-tighten as this risks damaging the wall plate.

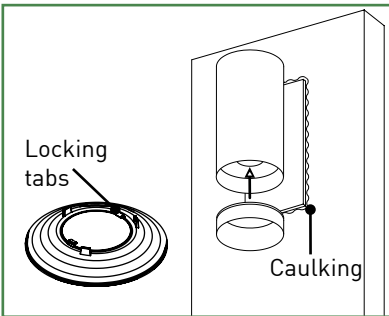

STEP 4

Replace optic and baffle assembly. Ensure both locking tabs of optic engage with LED base and twist clockwise to secure.

Gently push baffle assembly into Sconce body.

STEP 5

Apply silicone caulk around wall plate to fully seal against wall.

Note: Only applies to exterior applications.

G. PS-RMT REMOTE POWER SUPPLY

Note: Up / Down light configurations require 2 remote power supplies.

Determine preferred mounting location, verifying fixture falls within allowable wire capacity distance from selected power supply.

Run suitably sized two-pair wire between remote driver and cylinder location, following installation guidelines for terminating, as applies.

Note: Secondary wiring is polarized (+ / -) and must be terminated correctly at both ends for proper operation. It is recommended to use Red (+) and Black (-) wires to avoid confusion. Additionally, a ground wire should not accompany secondary run wires.

Failure to use the appropriate gauge wire for the run length required and to ensure proper polarity is observed will cause damage to the unit and void the warranty.

Access splice compartment by removing retaining screws, then tilting cover slightly back and away from base (**fig.1**).

Mount transformer back plate assembly to suitable substrate using customer supplied screws (**fig.2**).

Insert line voltage wiring / conduit into line side of splice compartment and secondary voltage wiring / conduit into secondary side of splice compartment utilizing appropriate strain relief or connector (**fig.3**).

Note: Consult wiring diagrams on page 7, in accordance with the applicable driver.

Join structured building wires to corresponding driver wires with suitable customer supplied wire connecting device, ensuring proper polarity is observed with secondary wires.

Push all wires and wire connections into splice compartment and reinstall splice compartment cover by aligning tab and slot, ensuring no wires are pinched by cover, installing retaining screws (**fig.3**).

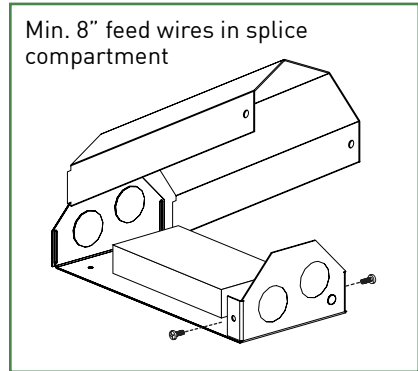

Fig.1

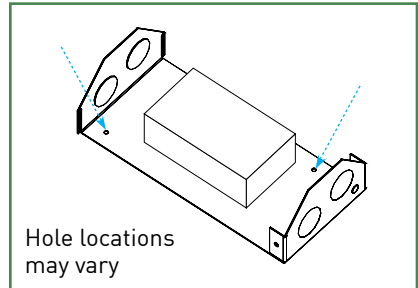

Fig.2

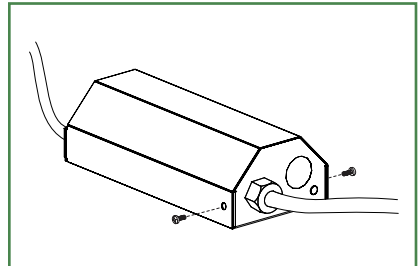

Fig.3

I. SERVICING FIXTURE

Important: Before servicing or maintaining fixture, disconnect electrical power at main switch or circuit breaker. Additionally, review notes in Sections A and B and refer to figures in main installation instructions when necessary.

1. EXCHANGING LOWER OPTIC / EFFECTS DEVICE

- A. Remove baffle assembly by attaching suction tool to lens and pulling down.
- B. To change optic, carefully grab and twist counter-clockwise to remove and clockwise to secure. Ensure that both feet of optic properly engage LED base.
- C. To change effects device, install new baffle assembly with preferred effects device.
- D. Install baffle by pushing up into fixture aperture.

2. EXCHANGING UPPER OPTIC / EFFECTS DEVICE

- A. Remove upper effects device by removing the four screws on top of fixture. Discard o-ring.
- B. To change optic, grab and twist counter-clockwise to remove and clockwise to secure. Ensure that both feet of optic properly engage LED base.
- C. Install new o-ring and effects device with four new screws supplied from factory.

3. REPLACING LOWER LED ASSEMBLY

- A. Remove sconce from wall, see Section F on page 3.
- B. Remove baffle assembly by using suction tool and pulling down.
- C. Grab optic and twist counter-clockwise to remove.
- D. Remove the four outer screws on the LED engine assembly and uncouple the quick connector.
- E. Replace with new OEM LED assembly sourced through Lucifer Lighting by coupling the quick connector and securing with four screws.
- F. Reinstall sconce, see Section F on page 3.

4. REPLACING UPPER LED ASSEMBLY

- A. Remove sconce from wall, see Section F on page 3.
- B. Remove upper effects device by removing the four screws on top of fixture. Discard o-ring.
- C. Grab optic and twist counter-clockwise to remove.
- D. Remove the three outer screws on the LED engine assembly and uncouple the quick connector.
- E. Replace with new OEM LED assembly sourced through Lucifer Lighting by coupling the quick connector and securing with three screws.
- F. Reinstall sconce, see Section F on page 3.

5. REPLACING INTEGRAL DOWNLIGHT (DF) DRIVER

- A. Remove sconce from wall, see Section F on page 3.
- B. Remove top cover plate by removing the four screws on top of fixture.
Discard o-ring.
- C. Remove the screw securing the driver to sconce, carefully lift up and uncouple the quick connector.
- D. Replace with new OEM Driver assembly sourced through Lucifer Lighting by feeding line / control wiring through the mounting plate, coupling the quick connector, and securing with screw.
- E. Install the new o-ring and top cover plate with four new screws supplied from factory.
- F. Reinstall sconce, see Section F on page 3.

6. REPLACING INTEGRAL UP / DOWNLIGHT (UP) DRIVER

- A. Remove sconce from wall, see Section F on page 3.
- B. Remove baffle assembly by using suction tool and pulling down.
- C. Grab optic and twist counter-clockwise to remove.
- D. Remove the four outer screws on the LED engine assembly and uncouple the lower quick connector.
- E. Carefully pull the drive out of the sconce and uncouple the upper quick connector
- F. Replace with new OEM Driver assembly sourced through Lucifer Lighting by coupling the upper quick connector, feeding line / control wiring through the mounting plate, and slide the driver into the sconce.
- G. Couple the lower quick connector and reinstall the LED engine assembly securing with the four screws previously removed.
- H. Reinstall sconce, see Section F on page 3.

I. REMOTE DRIVER WIRING DETAIL

WIRING DIAGRAM FOR RP1 DRIVER

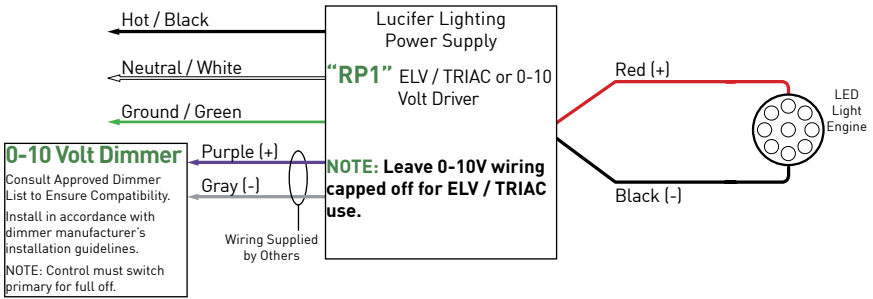

WIRING DIAGRAM FOR LINE DIMMING

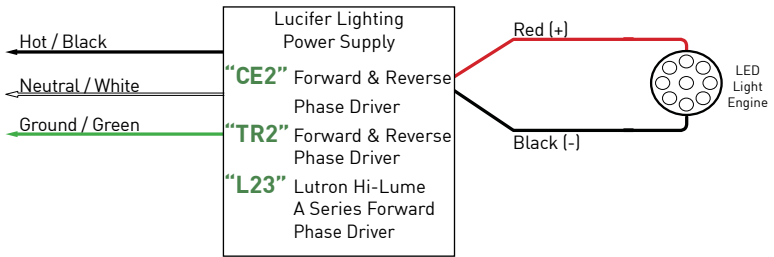

WIRING DIAGRAM FOR ECOSYSTEM AND DIGITAL CONTROL

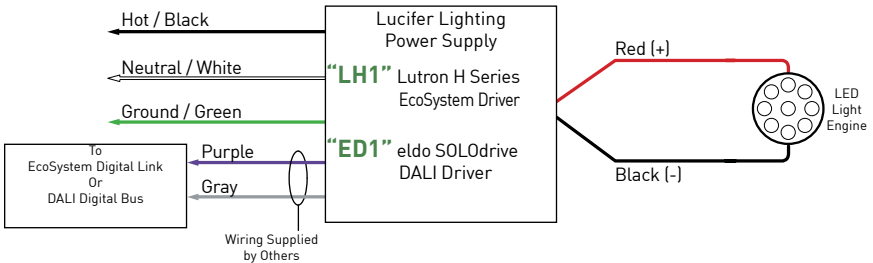

WIRING DIAGRAM FOR ANALOG CONTROL

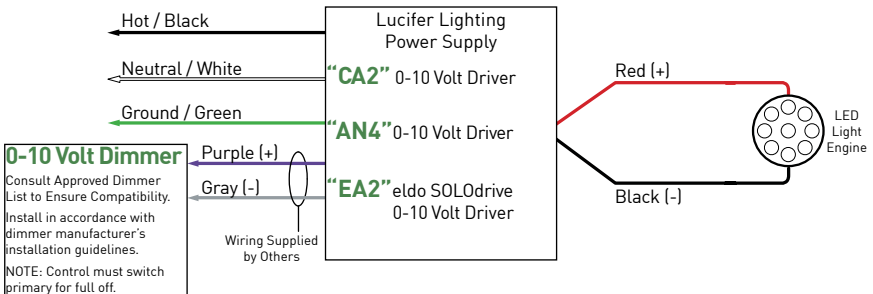



J. UL2108 INSTALLATION INFORMATION

Drive Current Information:

	80C			90C			97C			90W
	12A	19A	25A	10A	15A	20A	10A	12A	19A	13A
Minimum Vf	30.5	30.5	30.5	30.5	30.5	30.5	30.5	30.5	30.5	30.5
Maximum Vf	39	39	39	39	39	39	39	39	39	39
Current mA	250	400	550	250	350	500	250	350	500	14 - 350
Wattage W	8.2	13.6	19.4	8.2	13.6	19.4	8.2	13.6	19.4	13.6

Node Compatibility:

Manufacturer	Model Number
 <small>Enabling Smart Buildings™</small>	NP50-60-C-F-5
	180996-1001 180996-1002 180996-2001 180996-2002
	1 Channel Node, POE-LN2-1U-E 2 Channel Node, POE-LN2-2U-E 4 Channel Node, POE-LN2-4U-E

LIMITED WARRANTY

LUCIFER LIGHTING COMPANY (Seller) warrants that for a period of one (1) year from date of sale to the first non-retail purchaser, Seller will repair or replace, at the Seller's sole option, free of charge, any defective products purchased from Seller provided that prior authorization is obtained from the Seller and the products are sent prepaid to the Seller's manufacturing facility. Lamps are not warranted or guaranteed in any manner for any length of time, except LED lamp modules and power supplies used in Seller's recessed, surface mount and exterior lighting fixtures, are warranted to operate with 70% lumen maintenance from the date of sale by Seller for five (5) years. LED MR-16 style lamps supplied by Seller are only warranted as provided by their original maker. Please refer to the following limiting conditions.

1. The Citizen, Bridgelux, Xicato, Sharp and Lumenetix LED lamp modules provided by Seller are only suitable for use in ceiling or plenum conditions where the maximum operating temperature of the module does not exceed 90°C (194°F) and/or the ambient temperature does not exceed 40°C (104°F) or lower threshold as featured on Seller's product specification literature.
2. These terms only cover the power supply (if purchased from Seller) and Citizen, Bridgelux, Xicato, Sharp, and Lumenetix LED modules.
3. If installed outdoors, the power supply must always be shielded from direct sunlight. The power supply cannot be installed in areas where liquids may pool.
4. The end user must ensure that the AC input voltage has measures in place to prevent lightning strike surges and that large load shift surges are reduced or eliminated prior to the input of the power supply. Power supplies returned with this type of damage are not covered under Seller's Limited Warranty.
5. Seller reserves the right to physically evaluate the LED module and driver supplied by Seller for compliance with these conditions. An end user's refusal to return such fixture articles shall void Seller's Limited Warranty.
6. The LED module will be considered in working condition and therefore not warrantable if it meets or exceeds 70% of its original flux and remains within a range of 3 div.
7. The color temperature of the Citizen, Bridgelux, Xicato, Sharp and Lumenetix LED module is guaranteed to remain within a range of 3 div for a period of five (5) years from date of sale by Seller.
8. Any tampering or disassembly of the LED module or LED heat-sink assembly without Seller's prior written consent will immediately void the warranty.

Where Seller's fixtures are used in conjunction with drivers/power supplies sourced by others and/or where POE (power over ethernet) systems are present, Seller's warranty will only apply to the Seller supplied lighting fixtures. In all instances where drivers/power supplies and/or POE are by others, the responsibility to confirm the selected power supply(s) conforms to operating parameters of Seller's fixtures shall be the responsibility of others. Approved parameters (involving voltage, current, and power quality for the selected fixtures and outputs) will be provided by Seller upon request, however the parameters should not be considered exhaustive for the purpose of the warranty and represents a good faith effort by Seller to support its customers. All warranty claims are subject to Seller's review and if Seller determines the root cause of the issue involves supplied power supply(s) by others, Seller's warranty shall not be applicable. Further, in such events of supplied power supply(s) by others, Seller makes no guarantee as to fixture operating performance (startup time, flicker, shimmer, pop-on/pop-off, dimming, etc.). In no event shall Seller's obligations under this warranty extend beyond the initial cost of the products and, accordingly, consequential damages arising out of any claimed product defect are expressly excluded. This Warranty does not cover the costs, if any, in re-installation of products serviced under this Warranty. This Warranty does not cover damage or failure caused by acts of God, abuse, misuse, abnormal usage, or use in violation of any applicable standard, code or instructions for use in installations including those contained in the latest National Electrical Code (NEC), the standards for safety of Underwriters Laboratory, Inc. (UL), standards for the American National Standards Institute (ANSI) or, in Canada, the Canadian Standards Association (CSA), or, in the European Union, the Conformité Européenne (CE Marking), faulty installation, or any repairs or modifications other than those made by the Seller. This Warranty does not cover damage or failure caused by abnormal spikes in power, dirty power, and light fixtures used with power supplies or other products not supplied by Seller, nor shall it apply to defects for which written notice thereof is not received by Seller.

In the event that any of the terms of this Warranty are in conflict with any rule of law or statutory provision or otherwise unenforceable under the laws or regulations of any government or subdivision thereof, such terms shall be deemed stricken from this Warranty, but such invalidity or unenforceability shall not invalidate any of the other terms of this Warranty and this Warranty shall continue in force.

EXCEPT AS TO SELLER'S WARRANTY OF REPAIR OR REPLACEMENT SET FORTH ABOVE, THERE ARE NO UNDERSTANDINGS, AGREEMENTS, REPRESENTATIONS, OR WARRANTIES, EXPRESS OR IMPLIED (INCLUDING ANY REGARDING THE MERCHANTABILITY OR FITNESS FOR A PARTICULAR PURPOSE, AND NON-INFRINGEMENT, AND ANY WARRANTIES ARISING FROM A COURSE OF DEALING, USAGE, OR TRADE PRACTICE), RESPECTING LUCIFER LIGHTING COMPANY PRODUCTS. THIS WARRANTY IS THE PURCHASER'S SOLE AND EXCLUSIVE REMEDY AGAINST THE SELLER FOR THE REPAIR OR REPLACEMENT AT SELLER'S OPTION OF DEFECTIVE LUCIFER LIGHTING PRODUCTS. UNDER NO CIRCUMSTANCES SHALL SELLER BE LIABLE FOR ANY LOSS OR DAMAGE, DIRECT OR CONSEQUENTIAL, ARISING OUT OF THE USE OF, OR INABILITY TO USE, THE PRODUCTS SOLD HEREUNDER.

For service under this warranty, please provide the original date of sale and nature of difficulty being experienced. All service matters should be directed to:

[07272020]

3750 IH 35 North

San Antonio, Texas 78219 USA

[PH] +1 210 227 7329

[FAX] +1 210 227 4967

www.luciferlighting.com

LUCIFER[®]
LIGHTING COMPANY

©2020 Lucifer Lighting Company

As part of its policy of continuous research and product development, the Company reserves the right to change or withdraw specifications without prior notice.