

SQUILINDER SURFACE MOUNT

SQUILINDER LED LUMINAIRE SQ / SP SERIES

INSTALLATION

Before beginning any installation, disconnect electrical power at main switch or circuit breaker.

A. CAUTION

To reduce the risk of fire, electric shock, and potential damage to recessed housing assembly when electrical power is re-connected, DO NOT ATTEMPT TO CONNECT the following on branch circuit serving recessed downlight assembly:

- Motors
- Power tools
- Extension cords
- Appliances or similar electronics

Fixtures to be mounted in conditions where ambient temperatures do not exceed 40°C.

Ensure AC input voltage is protected against surges & load shifts prior to power supply input.

B. SAFETY INSTRUCTIONS

1. Read installation instructions completely before attempting installation.
2. Failure to follow instructions may result in improper installation and void warranty.
3. Contact Lucifer Lighting Company with any questions or concerns before beginning any installation.
4. Ensure qualified electrician will perform all electrical procedures.
5. Disconnect electrical power circuit before attempting to install Squilinder, or if adding to or changing configuration of Squilinder assembly.
6. CAUTION: When fixture is on for long periods the Squilinder surface will be hot. Take care when making adjustments.

This product must be installed in accordance with applicable electrical and installation codes by a person familiar with the construction and operation of the product and the hazards involved. "CAUTION- RISK OF FIRE"

C. DESCRIPTION

Surface mounted Squilinder with dimmable LED module and optional integral driver. SQ2-AD has standard 90° tilt and 357° rotation; fixed unibody Squilinders also available. Pendant Squilinders feature field cuttable cable (section E, page 3).

D. MOUNTING

SQ2-AD adjustable Squilinders may be wall mounted in Dry / Damp locations only. Pendant Squilinders accommodate flat or sloped ceiling conditions.

SQ2-JBMP:

Specified to mount flush with minimalist transition to standard j-box installed behind substrate (section D.1, page 2).

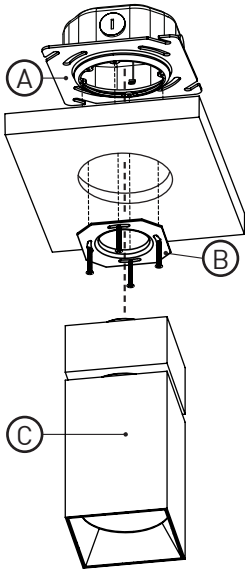

D.1 SQ2-JBMP

For flush standard mount featuring a minimalist transition from standard 4/0 or 4" square j-boxes installed behind substrate. Specify SQ2-JBMP.

NOTE: The J-box mounting plate (SQ2-JBMP) must be installed prior to substrate.

PARTS IDENTIFICATION

Qty.	Description	Part ID
1	J-box mounting plate	A
1	Mounting adaptor plate	B
1	Squilinder assembly	C

NOTE: Mounting adaptor plate ships with Squilinder assembly.

Junction Box
(supplied by
others)

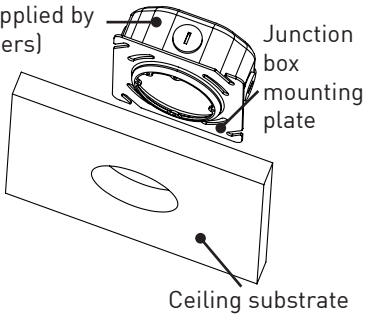

STEP 1

Universal junction box mounting plate attaches to standard 4" octagon or 4" square junction box before ceiling substrate is installed.

SQ2-JBMP: 2.875"(73mm) cutout

STEP 2

With substrate installed and appropriate cutout made, attach mounting adaptor plate with screws provided; ensuring plate is seated firmly to finished ceiling plane.

NOTE: Skip step 2 for drop kit installations

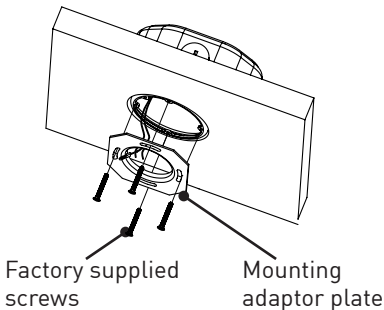

E. SQ2-DK (DROP KIT)

For suspending cylinder at varying heights and on sloped ceilings up to 45°. Must be installed in conjunction with the SQ2-JBMP (Section D.1),

NOTE: The SQ2-JBMP must be installed prior to substrate.

PARTS IDENTIFICATION

Part ID	Description	Qty.
A	Mounting plate	1
B	Mounting plate screws	2
C	Pressure plate	1
D	Ball swivel	1
E	Magnetic concealer plate	1
F	Stem	1-3
G	Lower canopy	1
H	Safety lanyard	1
I	Retaining collar	1
J	Set Screws	3
K	Threaded Nipple	1-2
L	Clamping bracket	1
M	Clamping bracket screw	1

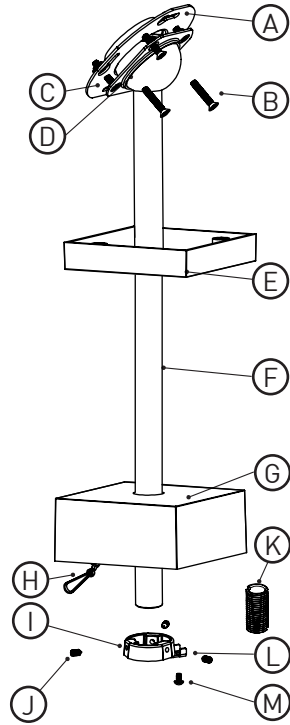

STEP 1

Cut stem to length as required at 90° angle from end where the lower canopy will be connected.

Installer Tip: Stem is recessed into lower canopy 3/8", add 3/8" to total length prior to cutting stem.

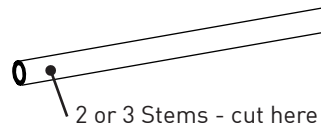
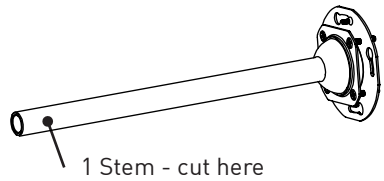

STEP 2

Connect stems as required by threading stems together.

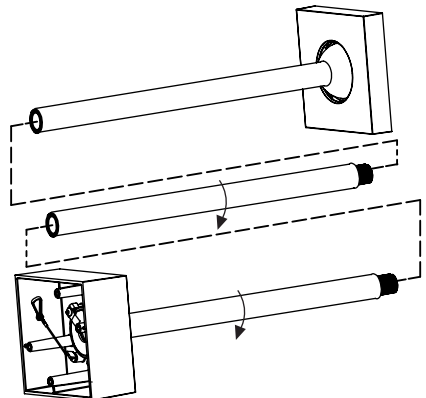

STEP 3

Feed line and control wiring (if required) through stem(s) from the mounting plate to the lower canopy; wiring supplied by others.

Installer Tip: Recommend using solid 12 AWG THHN and 18/2 for line voltage and control wiring. Wrap wiring tight with electrical tape and push through stems.

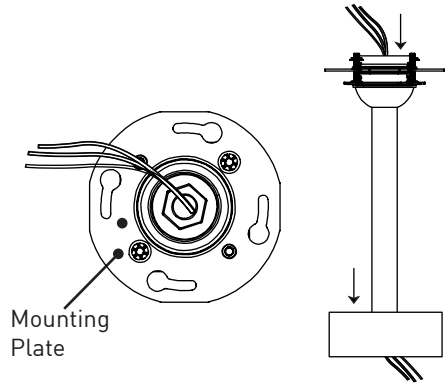

STEP 4

Ensure magnetic concealer plate is in place and feed lower canopy onto stem, install retaining collar on end of stem and secure with three factory supplied set screws. Ensure bushing is secured to stem.

WARNING: Failure to ensure set screws are adequately tightened may result in failure of bushing.

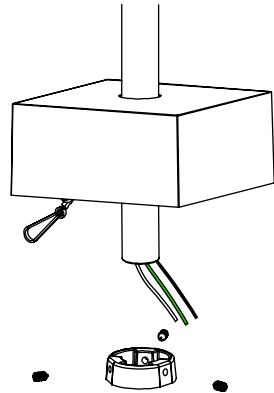

STEP 5

Install clamping bracket to lower canopy by starting supplied screw, rotate bracket over retaining collar and tighten screw.

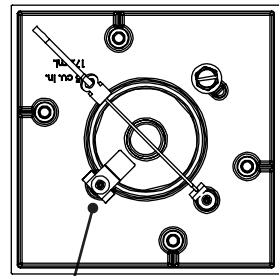

Clamping Bracket

STEP 6

Install mounting adaptor plate to lower canopy using supplied screws, ensuring it is square with the canopy.

NOTE: Mounting adaptor plate and screws ship with Squilinder assembly.

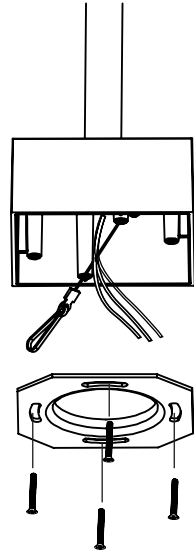

STEP 7

Loosen pressure plate screws slightly prior to installation.

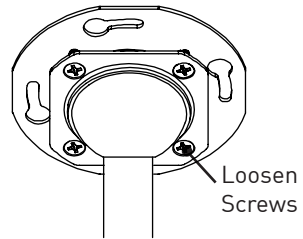

STEP 8

Attach safety lanyard and wiring from line / mains source as indicated with suitable wire-nuts or similar connectors. For 0-10V dimming option, use gray and purple wires as shown. Push connections, excess wiring, and lanyard into junction box.

NOTE: CMJB application not shown.

Black Wire	- Line
White	- Neutral
Green	- Ground
Purple	- Dim +
Gray	- Dim -

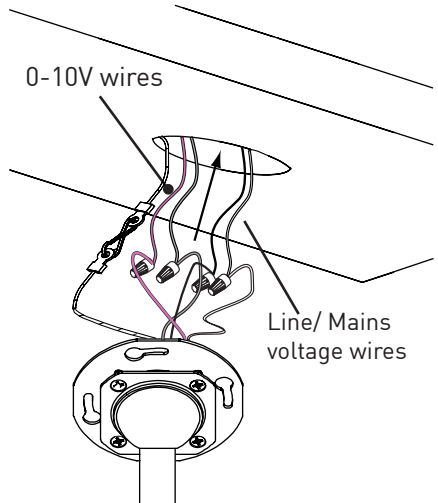

STEP 9

Attach drop kit mounting plate to SQ2-JBMP using supplied screws. Reference section D.1 for complete JBMP installation instructions. Position drop kit mounting plate below ceiling cutout and attach to J box mounting plate with supplied screws.

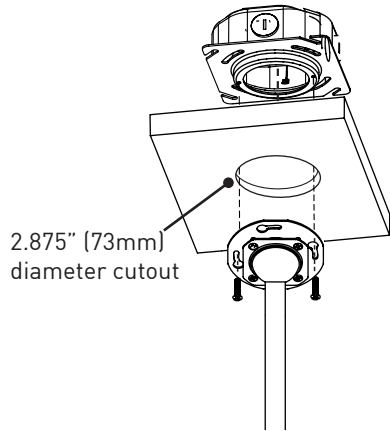

STEP 10

With drop kit installed and stem positioned vertically, UNIFORMLY tighten pressure plate screws and raise magnetic concealer plate.

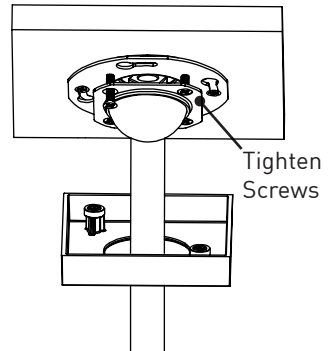

F. PENDANT CABLE ADJUSTMENT

For Pendant Squilinder installations where field adjustment of cable length is required, refer to following instructions.

STEP 1

Remove 4 screws located on top of Squilinder body using 0.050" Allen key.

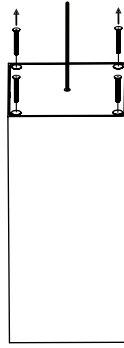

STEP 2

Remove lid from top of Squilinder body exposing wire nuts and cable knot.

STEP 3

Remove the 2 wire nutes connecting the cable wires and the LED wires. Make desired cut on pendant cable and tie a knot below lid to act as strain relief, ensure adequate amount of slack is allowed for wire connections. Strip orange and white wires located inside pendant cable and re-connect to LED wires using wire nuts. Orange to black and white to red.

Note: Leave white and orange wires 1" longer than cable to allow for connection to LED wires.

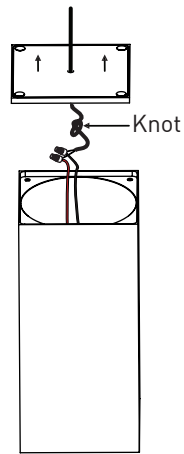

STEP 4

Reverse steps 1-2 to secure Squilinder body lid.

G. SQUILINDER WIRING AND MOUNTING

Note: If using remote power supply, see page 9.

STEP 1

Connect Squilinder and mounting plate safety lanyards together.

WARNING: Failure to attach safety lanyard may result in an unsafe condition.

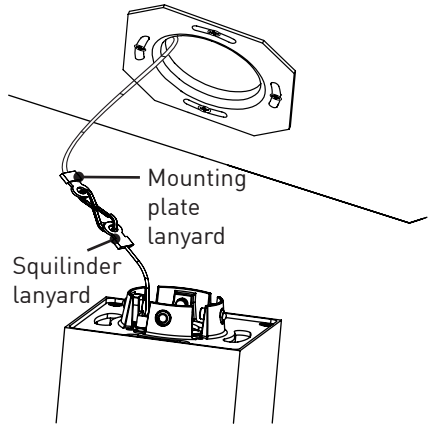

STEP 2

Attach wiring from line / mains source as indicated with suitable wire-nuts or similar connectors. For 0-10V dimming option, use gray and purple wires as shown. Push connections, excess wiring, and lanyard into junction box.

- Black Wire - Line
- White - Neutral
- Green - Ground
- Purple - Dim +
- Gray - Dim -

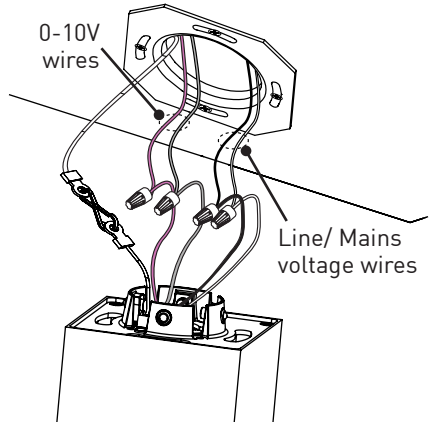

STEP 3

With safety lanyard and wiring completed, push Squilinder assembly into mounting adaptor plate until ball plungers engage.

Note: Audible snap may be heard when ball plungers engage.

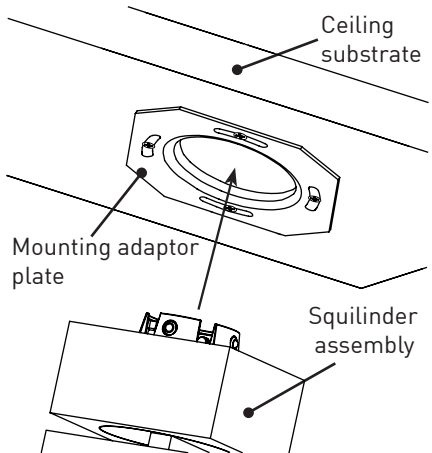

H. REMOTE POWER SUPPLY

Determine preferred mounting location, verifying that fixture falls within maximum allowed wiring distance (*Fig. 1*).

Run adequately sized two-pair wire between remote driver and housing, following installation guidelines for terminating as needed.

Note: Secondary wiring is polarized (+/-) and must be terminated correctly at both ends for proper operation. It is recommended to use Red (+) and Black (-) wires to avoid confusion. No ground wire necessary on secondary side.

Ensure proper polarity is observed as reversed polarity may damage the unit and may void the warranty.

Access splice compartment by removing retaining screws, then tilting cover slightly back and away from base (*Fig.2*).

Mount power supply back plate assembly to suitable substrate using customer-supplied screws (*Fig.3*).

Insert line voltage wiring/conduit into line side of splice compartment and secondary voltage wiring/conduit into secondary side of splice compartment, utilizing appropriate strain relief or connector.

Note: Consult wiring diagrams on page 11 for applicable driver type.

Join structured building wires to corresponding driver wires with suitable customer-supplied wire connecting device.

Push all wires and wire connections into splice compartment and reinstall splice compartment cover by aligning tab and slot, ensuring that no wires are pinched by cover. Install retaining screws (*Fig.3*).

Important: Ensure foam aperture insert is in place prior to commencing ceiling installation. Failure to comply may result in damage to the LED or optic.

Lutron Drivers: “L23” & “LH1”					
AWG Value	18	16	14	12	
Distance (m)	4.5	7.5	12	18	
Distance (ft)	15	25	40	60	
Philips Drivers: “TR2” & “AN4”					
AWG Value	20	18	16	14	12
Distance (m)	14	22	34	55	87
Distance (ft)	45	71	113	180	285
eldoLED Drivers: “ED1”, “LD1”, “LA2”, “EA2”					
AWG Value	20	19	18	17	16
Distance (m)	14	18	22	28	36
Distance (ft)	46	59	72	92	118

Fig.1

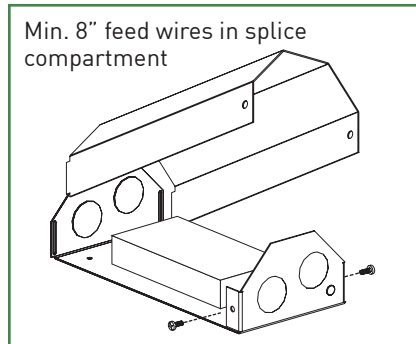

Fig.2

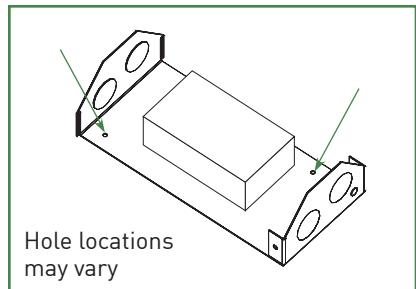

Fig.3

I. OPTIC AND BAFFLE / LENS REPLACEMENT

Optics and baffle / lens assemblies are interchangeable in the field.

STEP 1

Remove baffle assembly from Squilinder by securing suction tool (provided) to lens and gently pulling down to release (Fig 4.).

STEP 2

Carefully grab optic and twist counter-clockwise to remove.

STEP 3

Replace optic and baffle assembly. Ensure both locking tabs of optic engage with LED base and twist clockwise to secure. Apply even pressure to baffle assembly to secure into Squilinder body (Fig 5.).

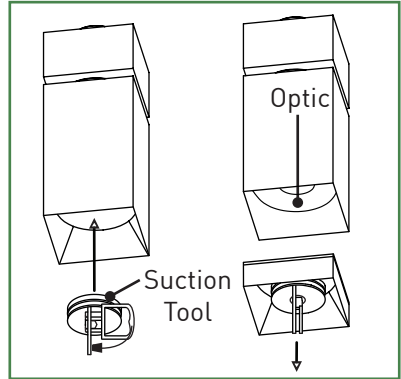

Fig.4

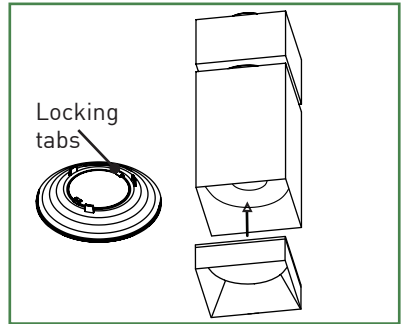

Fig.5

I. DRIVER REPLACEMENT

The following instructions describe how to remove and replace integral driver.

STEP 1

Remove 4 screws located on mounting plate of Squilinder canopy using Philips screw driver (Fig 6.).

STEP 2

Remove mounting plate to expose integral driver (Fig 7.). Lift driver out of Squilinder canopy and disconnect plastic connector by pressing on locking tab and pulling apart (Fig 8.).

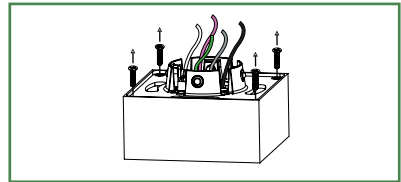

Fig.6

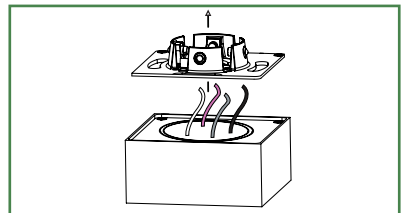

Fig.7

STEP 3

Connect plastic socket of replacement driver and lower into Squilinder enclosure with red and white wires facing downward.

STEP 4

Replace mounting plate, feeding driver's wires through center opening of mounting plate.

STEP 5

Reverse STEPS 1 to secure mounting plate and complete driver replacement.

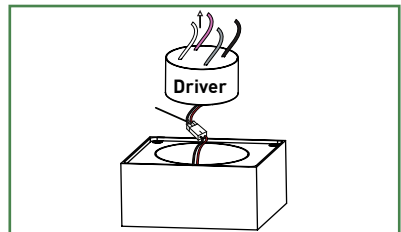
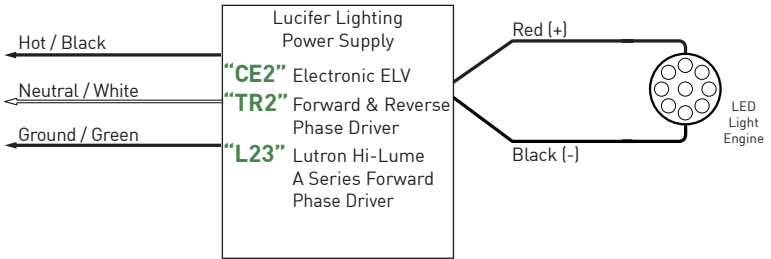

Fig.8

J. DRIVER WIRING DETAIL

WIRING DIAGRAM FOR LINE DIMMING



WIRING DIAGRAM FOR ECOSYSTEM AND DIGITAL CONTROL

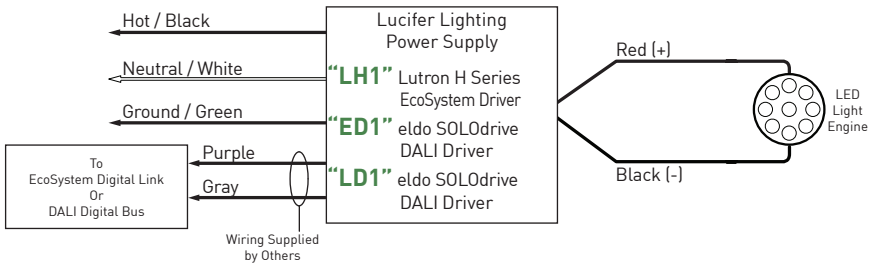

WIRING DIAGRAM FOR ANALOG CONTROL

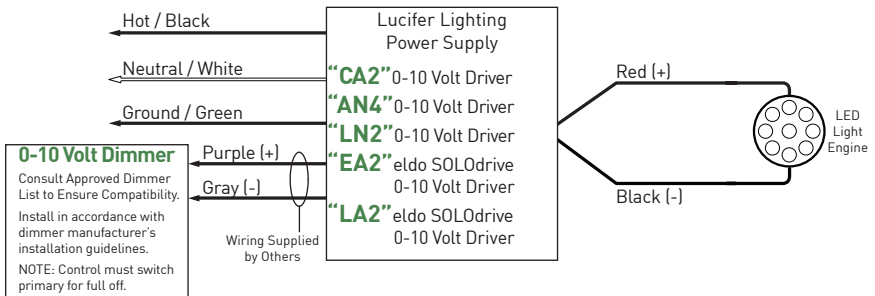

LIMITED WARRANTY

LUCIFER LIGHTING COMPANY (Seller) warrants that for a period of one (1) year from date of sale to the first non-retail purchaser, Seller will repair or replace, at the Seller's sole option, free of charge, any defective products purchased from Seller provided that prior authorization is obtained from the Seller and the products are sent prepaid to the Seller's manufacturing facility. Lamps are not warranted or guaranteed in any manner for any length of time, except LED lamp modules and power supplies used in Seller's recessed, surface mount and exterior lighting fixtures, are warranted to operate with 70% lumen maintenance from the date of sale by Seller for five (5) years. LED MR-16 style lamps supplied by Seller are only warranted as provided by their original maker. Please refer to the following limiting conditions.

1. The Citizen, Bridgelux, Xicato, Sharp and Lumenetix LED lamp modules provided by Seller are only suitable for use in ceiling or plenum conditions where the maximum operating temperature of the module does not exceed 90°C (194°F) and/or the ambient temperature does not exceed 40°C (104°F) or lower threshold as featured on Seller's product specification literature.
2. These terms only cover the power supply (if purchased from Seller) and Citizen, Bridgelux, Xicato, Sharp, and Lumenetix LED modules.
3. If installed outdoors, the power supply must always be shielded from direct sunlight. The power supply cannot be installed in areas where liquids may pool.
4. The end user must ensure that the AC input voltage has measures in place to prevent lightning strike surges and that large load shift surges are reduced or eliminated prior to the input of the power supply. Power supplies returned with this type of damage are not covered under Seller's Limited Warranty.
5. Seller reserves the right to physically evaluate the LED module and driver supplied by Seller for compliance with these conditions. An end user's refusal to return such fixture articles shall void Seller's Limited Warranty.
6. The LED module will be considered in working condition and therefore not warrantable if it meets or exceeds 70% of its original flux and remains within a range of 3 div.
7. The color temperature of the Citizen, Bridgelux, Xicato, Sharp and Lumenetix LED module is guaranteed to remain within a range of 3 div for a period of five (5) years from date of sale by Seller.
8. Any tampering or disassembly of the LED module or LED heat-sink assembly without Seller's prior written consent will immediately void the warranty.

Where Seller's fixtures are used in conjunction with drivers/power supplies sourced by others and/or where POE (power over ethernet) systems are present, Seller's warranty will only apply to the Seller supplied lighting fixtures. In all instances where drivers/power supplies and/or POE are by others, the responsibility to confirm the selected power supply(s) conforms to operating parameters of Seller's fixtures shall be the responsibility of others. Approved parameters (involving voltage, current, and power quality for the selected fixtures and outputs) will be provided by Seller upon request, however the parameters should not be considered exhaustive for the purpose of the warranty and represents a good faith effort by Seller to support its customers. All warranty claims are subject to Seller's review and if Seller determines the root cause of the issue involves supplied power supply(s) by others, Seller's warranty shall not be applicable. Further, in such events of supplied power supply(s) by others, Seller makes no guarantee as to fixture operating performance (startup time, flicker, shimmer, pop-on/pop-off, dimming, etc.). In no event shall Seller's obligations under this warranty extend beyond the initial cost of the products and, accordingly, consequential damages arising out of any claimed product defect are expressly excluded. This Warranty does not cover the costs, if any, in re-installation of products serviced under this Warranty. This Warranty does not cover damage or failure caused by acts of God, abuse, misuse, abnormal usage, or use in violation of any applicable standard, code or instructions for use in installations including those contained in the latest National Electrical Code (NEC), the standards for safety of Underwriters Laboratory, Inc. (UL), standards for the American National Standards Institute (ANSI) or, in Canada, the Canadian Standards Association (CSA), or, in the European Union, the Conformité Européenne (CE Marking), faulty installation, or any repairs or modifications other than those made by the Seller. This Warranty does not cover damage or failure caused by abnormal spikes in power, dirty power, and light fixtures used with power supplies or other products not supplied by Seller, nor shall it apply to defects for which written notice thereof is not received by Seller.

In the event that any of the terms of this Warranty are in conflict with any rule of law or statutory provision or otherwise unenforceable under the laws or regulations of any government or subdivision thereof, such terms shall be deemed stricken from this Warranty, but such invalidity or unenforceability shall not invalidate any of the other terms of this Warranty and this Warranty shall continue in force.

EXCEPT AS TO SELLER'S WARRANTY OF REPAIR OR REPLACEMENT SET FORTH ABOVE, THERE ARE NO UNDERSTANDINGS, AGREEMENTS, REPRESENTATIONS, OR WARRANTIES, EXPRESS OR IMPLIED (INCLUDING ANY REGARDING THE MERCHANTABILITY OR FITNESS FOR A PARTICULAR PURPOSE, AND NON-INFRINGEMENT, AND ANY WARRANTIES ARISING FROM A COURSE OF DEALING, USAGE, OR TRADE PRACTICE), RESPECTING LUCIFER LIGHTING COMPANY PRODUCTS. THIS WARRANTY IS THE PURCHASER'S SOLE AND EXCLUSIVE REMEDY AGAINST THE SELLER FOR THE REPAIR OR REPLACEMENT AT SELLER'S OPTION OF DEFECTIVE LUCIFER LIGHTING PRODUCTS. UNDER NO CIRCUMSTANCES SHALL SELLER BE LIABLE FOR ANY LOSS OR DAMAGE, DIRECT OR CONSEQUENTIAL, ARISING OUT OF THE USE OF, OR INABILITY TO USE, THE PRODUCTS SOLD HEREUNDER.

For service under this warranty, please provide the original date of sale and nature of difficulty being experienced. All service matters should be directed to:

[052920]

3750 IH 35 North

San Antonio, Texas 78219 USA

[PH] +1 210 227 7329

[FAX] +1 210 227 4967

www.luciferlighting.com

LUCIFER[®]
LIGHTING COMPANY

©2020 Lucifer Lighting Company

As part of its policy of continuous research and product development, the Company reserves the right to change or withdraw specifications without prior notice.